

Shaped Charge DYNAWELL 9g Puncher TTG Strip St

Type	Part No.	Classification	CE No.	UN No.	D.O.T.
RDX	2314034	1.4S	0080.EXP.06.0014	0441	EX200602068
HMX	2314035	1.4S	0080.EXP.06.0014	0441	EX200602068
HNS	on request	1.4S	0080.EXP.05.0014	0441	EX200602068

Technical Drawing
(all dimensions in mm)

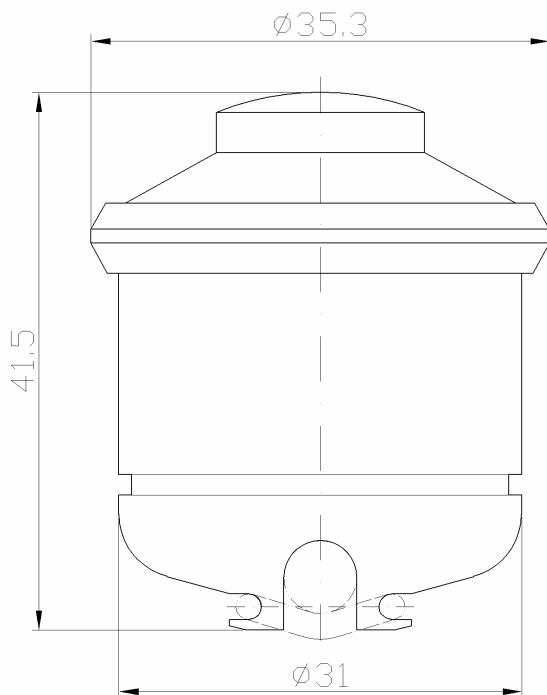

Technical Information

APPLICATION:

TEMPERATURE RESISTANT BIG HOLE PUNCHER SHAPED CHARGE FOR USE IN THROUGH TUBING STRIP GUN SYSTEMS FOR OILFIELD APPLICATIONS.

RECOMMENDED FOR WALL THICKNESS OF 6.5mm TO 10mm.

AVERAGE HOLE SIZE IN 6.5mm THICK TUBING WALL IS 24mm WITHOUT DAMAGE TO CASING IN 35mm DISTANCE

EXPLOSIVES CONTENT:

9g

SHAPED CHARGE TYPE:

BIG HOLE PUNCHER SHAPED CHARGE WITH STEEL CASE, WITH THREAD AND DETONATING CORD HOLDER.

PRESSURE RATING:

100 MPa / 14,500 psi

TEMPERATURE RESISTANCE:

RDX:	165 ° C / 1 h	330 ° F / 1 h
HMX:	205 ° C / 1 h	400 ° F / 1 h
HNS:	260 ° C / 1 h	500 ° F / 1 h

DEBRIS/CHARGE:

62g / 2.19oz

STRIP GUN CONFIGURATION:

GUN SIZE	SHOT DENSITY		PHASING
	["] [mm]	[spf] [spm]	
1 11/16	43	4 13	0
1 11/16	43	6 20	0

SHELF LIFE:

5 YEARS AT STORAGE CONDITION:
+ 5 ° C TO + 30 ° C + 41 ° F TO + 86 ° F
max. 65 % RELATIVE HUMIDITY
GOOD VENTILATION

DISPOSAL:

SHAPED CHARGES SHOULD BE DESTROYED ONLY BY AUTHORISED PERSONS (ACCORDING TO NATIONAL LAW AND REGULATION).

Packing Information

Quantity per box	50	pcs
Gross weight per box	9.0	kg
Net weight per box	6.8	kg
NEC per box	0.45	kg
Dimensions of box	40 x 40 x 16	cm
Product weight	136	g

Package Type	Carton + Vacuum Bag	TD P-P-I	Revision: IK18003AC
--------------	---------------------	----------	---------------------